

CENTAMAX[®]-B

Torsionally soft couplings with precompression for independently mounted units on rigid or soft mounts

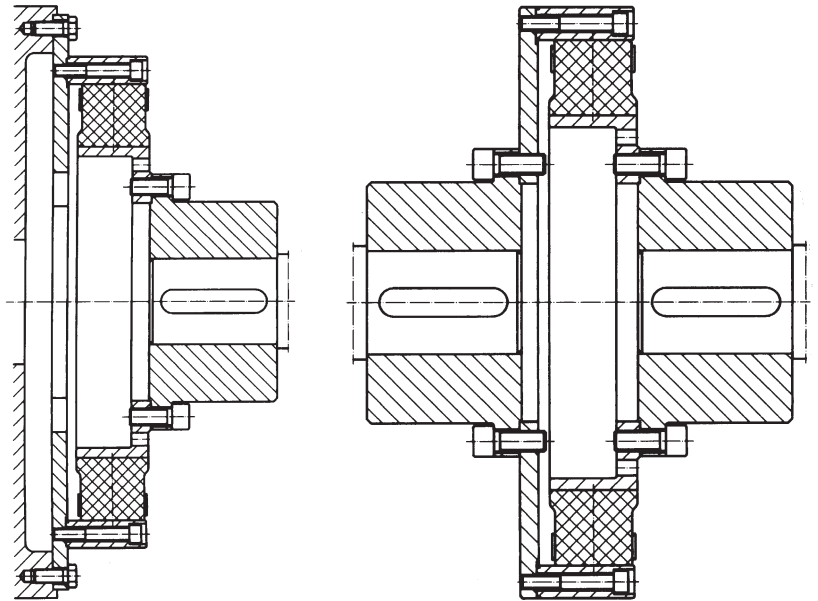

Power Transmission
Leading by innovation



For many years we have been supplying the „plug in“ type CENTAMAX series S for flange mounted drives. This series is described in detail in our catalog CM-S.

In this leaflet we describe the CENTAMAX series B, which adds a further interesting series for independently mounted drives. We have delivered many such couplings over the years.

The outstanding technical advantage is the precompression between the input flange and the rubber disc, which makes it free of backlash. The CENTAMAX-B is the only one of its kind of design with this feature.

The input flange is not made as a toothed cast aluminium ring, but as a steel plate with a series of single bolted steel bushes, which engage with the teeth of the rubber disc under substantial precompression.

Due to this backlash free, precompressed connection, the couplings are much more resistant to wear due to misalignment or torsional vibration especially when under low or no load conditions.

Furthermore the flexible element can be exchanged without disturbing the coupled shafts.

The CENTAMAX-B series are available for flywheel to shaft or shaft to shaft applications.

Important characteristics and advantages:

- torsionally very soft, precompressed, free of backlash
- linear stiffness characteristic
- torsional stiffness can be adjusted by choice of different shore hardness discs
- damps vibrations and shocks, compensates all kinds of misalignments
- temperature resistant rubber, good heat dissipation due to ventilation all over the disc
- suitable for high speeds, accepts large bores in the hubs
- no wearing parts, reliable long life, no maintenance
- compact short design – input flange to SAE J620 or with hub for the connection of 2 shafts
- simple, easy assembly, radial exchange of the element
- available with or without fail safe device

Typical areas of application:

nonflanged, independently mounted units for main propulsion or auxiliary drives, such as gensets, pumps, compressors and all kinds of front P.T.O.

The units can be mounted either on flexible or rigid mounts.

Technical data

Centamax Size	Shore Hardness	Nominal Torque	Max. Torque	Continuous Vibr. Torque at 10Hz	Allowable Energy Loss	Dyn. Torsional Stiffness
	Shore A	T_{KN} [Nm]	T_{Kmax} [Nm]	T_{kw} [Nm]	P_{kv} [W]	C_{Tdyn} [Nm/rad]
800-B	50	700	1400	280	105	2800
	60	850	1700	340		4200
	70	950	2000	380		6800
1200-B	50	1000	2000	400	150	4500
	60	1200	2400	480		7000
	70	1300	3000	520		11700
1600-B	50	1450	2900	580	220	6000
	60	1800	3600	720		9000
	70	2000	4000	800		15000
2400-B	50	2000	4000	800	300	10000
	60	2500	5000	1000		15000
	70	2800	6000	1120		25000
2600-B	50	2500	5000	1000	350	9000
	60	2700	6000	1080		12500
	70	3000	7000	1200		20000
2800-B	50	2800	6000	1120	360	25000
	60	3000	7500	1200		37500
	70	3200	8000	1280		63000
3500-B	50	3200	6500	1280	450	16000
	60	3500	8000	1400		24000
	70	3800	8500	1520		38000
4000-B	50	4000	8000	1600	500	34000
	60	4500	11000	1800		50000
	70	5000	12500	2000		80000
5000-B	50	4500	9000	1800	500	17000
	60	5000	10000	2000		27000
	70	6000	12000	2400		45000
6000-B	50	5400	11000	2160	750	28000
	60	6000	12000	2400		43000
	70	7000	15000	2800		77000
8000-B	50	8000	16000	3200	1000	60000
	60	9000	22000	3600		80000
	70	10000	25000	4000		130000
12000-B	50	12500	25000	5000	1500	79000
	60	14000	28000	5600		115000
	70	15000	30000	6000		188000

Typical application samples of CENTAMAX-B



Five Humber tugs are successfully using CENTAMAX-B to drive fire fighting pumps from the front PTO of the Diesel engine.

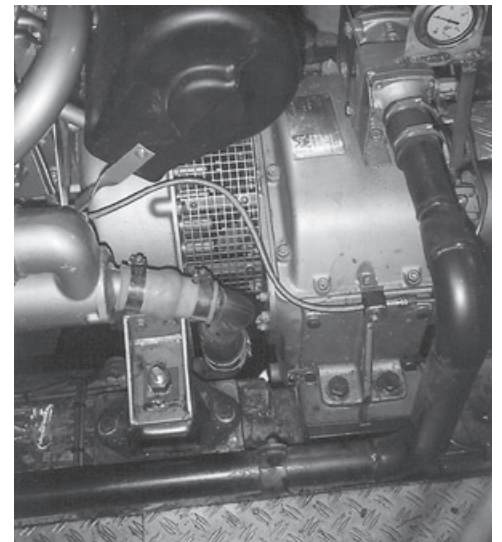

CENTAMAX-B for main propulsion between Diesel engine on soft mounts and marine gear on rigid mounts.

Dimensions, masses

Mass moments of inertia without fail safe device

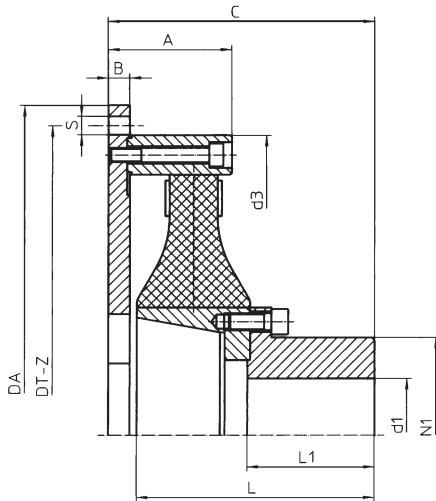

design „A“

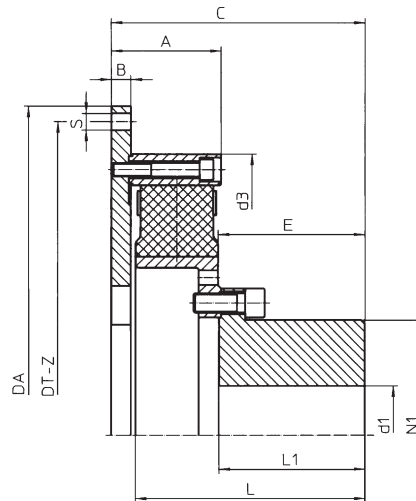

design „B“

Centamax Size	design	SAE J620	A	B	C	d ₁		d ₃	E	L	L ₁	N ₁	J [kgm ²]		m [kg]	
						min	max						primary	secondary	primary	secondary
800 BBE	A	11½ 14	87	15	150±2	20	65	326	64	130	66	100	0,334 0,705	0,028	17,3 26,1	9,3
1200 BBE	A	11½ 14	87	15	150±2	20	65	326	64	130	66	100	0,338 0,708	0,051	17,5 26,2	12,2
1600 BBE	A	14 16 18	87	15	188±2	30	100	425	88	168	90	140	0,933 1,214 1,618	0,106	28,1 32,7 38,1	19,8
2400 BBE	A	14 16 18	87	15	188±2	30	100	425	88	168	90	140	0,947 1,227 1,631	0,155	28,4 33,1 38,5	23,8
2600 BCE	B	14 16 18	98	15	212±2	35	105	454,5	103	183	105	154	1,056 1,337 1,741	0,201	27,9 32,5 37,9	27,4
2800 BCE	B	14 16 18	87	15	188±2	35	105	425	103	158	105	154	0,916 1,197 1,601	0,218	26,3 30,9 36,3	26,2
3500 BCE	B	14 16 18	98	15	212±2	35	105	454,5	103	183	105	154	1,076 1,357 1,761	0,221	28,7 33,3 38,7	28,2
4000 BCE	B	14 16 18	85	15	212±2	50	140	454,5	125	190	125	210	0,948 1,228 1,632	0,445	23,8 28,4 33,9	44,6
5000 BCE	B	14 16 18	111	15	227±2	35	105	454,5	103	198	105	154	1,177 1,468 1,862	0,223	30,2 34,8 40,2	31,1
6000 BCE	B	18 21	98	15	232±2	50	140	544	123	208	125	210	1,938 3,078	0,613	37,9 49,6	51,9
8000 BCE	B	18 21 24	111	18	265±1	70	170	576	151	236	150	235	2,805 4,325 5,621	1,058	47,1 62,6 73,1	70,5
12000 BCE	B	18 21 24	167 157 157	31 21 21	372±2 362±2 362±2	70	170	664 658 658	201	331	200	235	7,724 7,082 8,454	1,711	108 93,5 104	106

Dimensions to SAE J 620

SAE J620	D _A	D _T	Z	S
11½	352,4	333,4	8 x 45°	11
14	466,7	438,2	8 x 45°	13
16	517,5	489,0	8 x 45°	13
18	571,5	542,9	6 x 60°	17
21	673,1	641,4	12 x 30°	17
24	733,4	692,2	12 x 30°	19

Order Code

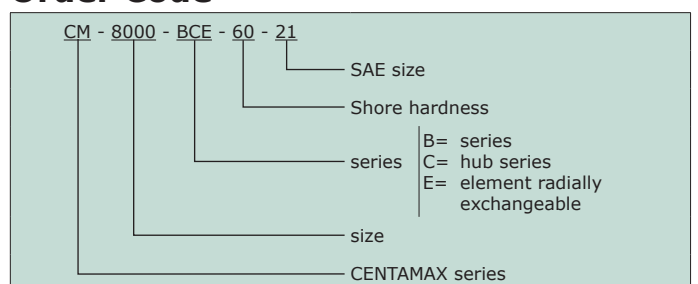

Dimensions, masses Mass moments of inertia with fail safe device

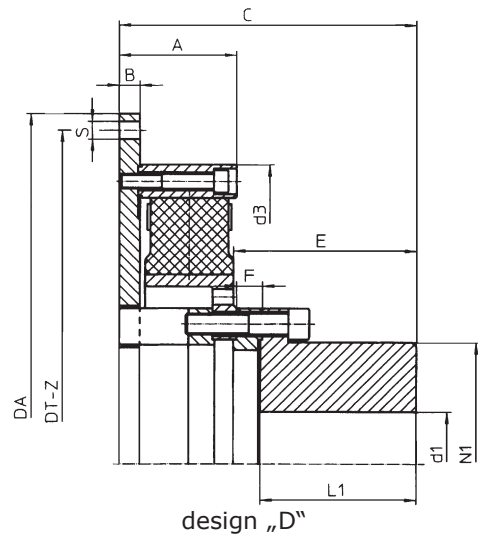
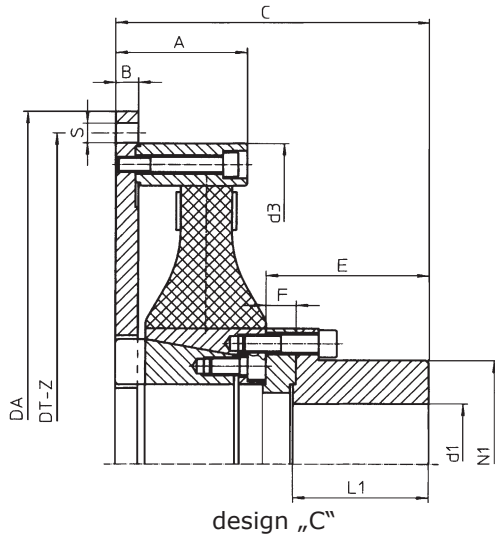

Centamax size	design	SAE J620	A	B	C	d ₁		d ₃	E	F	L ₁	N ₁	J [kgm ²]		m [kg]	
						min	max						primary	secondary	primary	secondary
800 BFE	C	11½ 14	87	15	184±2	20	65	326	98	20	80	100	0,334 0,705	0,039	17,3 26,1	14,4
1200 BFE	C	11½ 14	87	15	184±2	20	65	326	98	20	80	100	0,338 0,708	0,063	17,5 26,2	17,4
1600 BFE	C	14 16 18	87	15	208±2	30	100	425	108	20	90	140	0,933 1,214 1,618	0,149	28,1 32,7 38,1	28,5
2400 BFE	C	14 16 18	87	15	208±2	30	100	425	108	20	90	140	0,947 1,227 1,631	0,194	28,4 33,1 38,5	32,5
2600 BFE	D	14 16 18	98	15	250±2	35	105	454,5	148	20	130	154	1,056 1,337 1,741	0,209	27,9 32,5 37,9	30,5
2800 BFE	D	14 16 18	87	15	233±2	35	105	425	148	20	130	154	0,916 1,197 1,601	0,269	26,3 30,9 36,3	34,5
3500 BFE	D	14 16 18	98	15	250±2	35	105	454,5	148	20	130	154	1,047 1,328 1,732	0,289	28,7 33,3 38,7	35,4
4000 BFE	D	14 16 18	85	15	232±2	50	140	454,5	145	20	125	210	0,948 1,228 1,632	0,544	23,8 28,4 33,9	51,9
5000 BFE	D	14 16 18	111	15	265±2	35	105	454,5	148	20	130	154	1,177 1,468 1,862	0,229	30,2 34,8 40,2	34,2
6000 BFE	D	18 21	98	15	267±2	50	140	544	143	20	125	210	1,938 3,078	0,712	37,9 49,6	59,2
8000 BFE	D	18 21 24	111	18	290±1	70	170	576	176	25	150	235	2,805 4,325 5,621	1,281	47,1 62,6 73,1	82,9
12000 BFE	D	18 21 24	167 157 157	31 21 21	400±2 390±2 390±2	70 70	170 170	664 658 658	229 229	28 28	200 200	235 235	7,724 7,082 8,454	2,011	108 93,5 104	126

Order Code

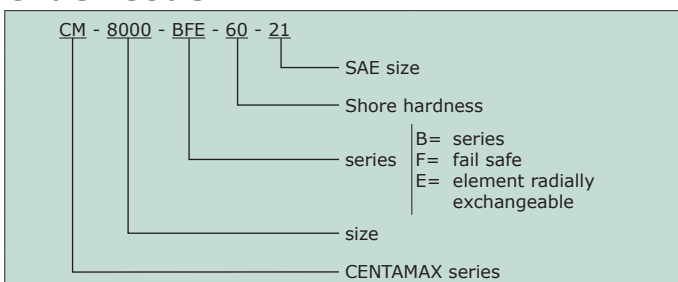

Without any details being given the hubs will be delivered prebored. All detail data, dimensions and information in this catalog is given without guarantee. We reserve the right to make amendments and improvements without notice. This catalog supersedes all previous catalogs and data sheets. This technical document has legal protection in accordance with DIN 34.

**Shaft to shaft types,
for radial change of element
Series BBEW
Series BCEW**

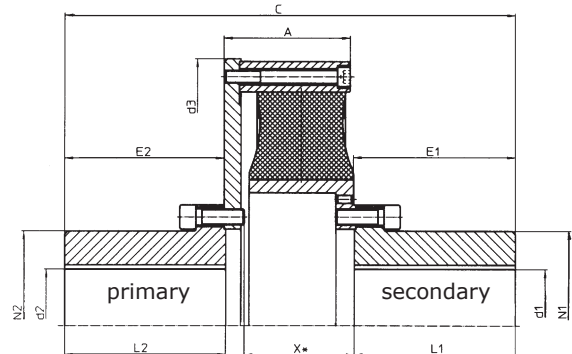

CENTAMAX size	A	C	d ₁ /d ₂		d ₃	E ₁	E ₂	L ₁ /L ₂	N ₁ /N ₂	X	J [kgm ²]		m [kg]	
			min	max							primary	secondary	primary	secondary
800 BBEW	87	214±2	20	65	330	64	64	66	100	69	0,303	0,028	21	9
1200 BBEW	87	214±2	20	65	330	64	64	66	100	69	0,307	0,051	22	12
1600 BBEW	87	276±2	30	100	430	88	88	90	140	83	0,821	0,106	38	19
2400 BBEW	87	276±2	30	100	430	88	88	90	140	83	0,835	0,155	39	23
2600 BCEW	99	316±2	35	105	458	103	103	105	154	88	1,166	0,201	49	27
2800 BCEW	88	294±2	35	105	430	103	103	105	154	66	0,919	0,218	44	26
3500 BCEW	99	316±2	35	105	458	103	103	105	154	88	1,186	0,221	50	28
4000 BCEW	86	336±2	50	140	458	125	123	125	210	68	1,252	0,445	62	44
5000 BCEW	112	330±2	35	105	458	103	103	105	154	102	1,287	0,223	53	31
6000 BCEW	99	356±2	50	140	548	123	123	125	210	88	2,203	0,613	76	51
8000 BCEW	113	414±2	70	170	578	151	148	150	235	96	3,411	1,058	104	70
12000 BCEW	157	560±2	70	170	665	201	198	200	235	137	7,545	1,711	164	106

X = min. space between the shaft ends for radial change of the rubber element.

Alignment of Coupling

The alignment of free mounted, nonflanged drives should be checked in the usual way, f.i. by checking the radial and angular misalignment between driving and driven side with a dial indicator.

As reference surface the inner hub should be used on one side and a machined surface of the flywheel or of the flywheel flange of the coupling or a hub on the other side. If the engine is placed on flexible mounts, then the alignment should be checked at the earliest 2 days after the engine has been put on its flexible mounts, because only then will these mounts have taken most of their perma-

nent set. In addition, the rigidly mounted driven unit should be placed about 0,3 mm lower than the flexibly mounted engine. In this way, upon further settling of the engine a misalignment improvement can be achieved and the engines position after some running time will not be essentially lower than the driven unit. Further settling of the engine is thus anticipated and compensated if necessary.

The alignment of flexibly mounted engines should be checked periodically.

Misalignment

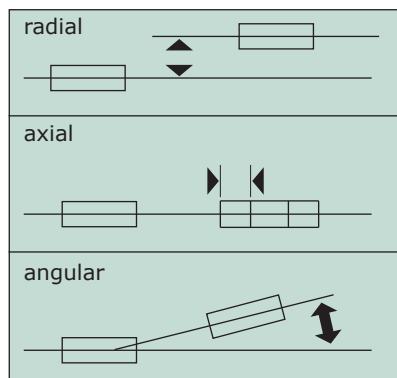

The couplings can accommodate the following maximum misalignment:

Axial: several mm (as stated in dimension tables)

Angular: 0,5 degrees

Radial: 1,0 mm

These values for angular and radial misalignment are based on 1500 rpm. For other speeds convert according the following diagram.

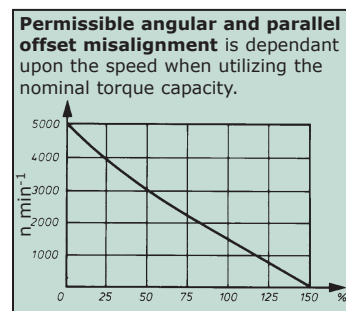

Since radial and angular misalignments cause continuous flexing of the rubber disc, it is advisable to keep the alignment as low as possible — better than above values — in order to ensure long coupling life and smooth running. For non flanged drives we recommend following effective range of max. misalignment:

angular: 0,2 degrees/radial: 0,5 mm
Above values are for continuous duty.

For short time (f.i. during starting and stopping the engine, at heavy sea, etc.) up to five times higher values for radial and angular misalignment are allowable.

Furthermore we offer the CENTAX-SEC range of couplings which easily compensate considerable misalignments without wear in the torque range up to 160 KNm.

Make use of our extensive experience and counsel for critical application.

Fitting instructions

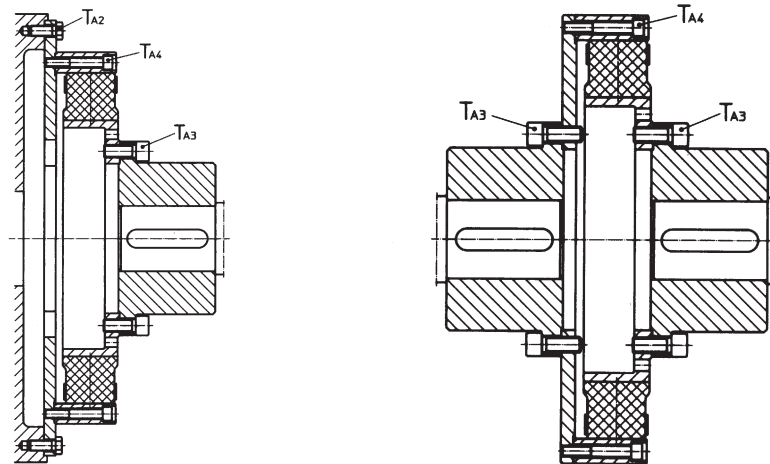

T_{A2} Tightening torque of bolts on flywheel flange – Types: BBE, BCE							
SAE		1 1/2	14	16	18	21	24
Metric bolts		M10	M12	M12	M16	M16	M18
8.8	T_{A2} [Nm]	46	79	79	195	195	245
Inch bolts		3/8 – 16	1/2 – 13	1/2 – 13	5/8 – 11	5/8 – 11	3/4 – 10
	T_{A2} [Nm]	42	102	102	203	203	366
	[inch-lbs.]	372	903	903	1797	1797	3240

These bolts are not included

T_{A3} Tightening torque of bolts on inner hub – Types: BBE, BCE, BBEW, BCEW						
coupling size	800 B 1200 B	1600 B 2400 B	2600 B 2800 B 3500 B	4000 B 5000 B 6000 B	8000 B	12000 B
bolts ISO 4762	M 10 10.9	M 12 10.9	M 16 10.9	M 16 10.9	M 20 10.9	M 20 10.9
tightening torque T_{A3} [Nm]	68	117	280	280	490	490
quantity	16	16	8	12	12	24

T_{A4} Tightening torque of bolts on flange – Types: BBE, BCE, BBEW, BCEW							
coupling size	800 B 1200 B	1600 B 2400 B 2800 B	2600 B 3500 B 6000 B	4000 B	5000 B	8000 B	12000 B
bolts ISO 4762	M 10x70 10.9	M 10x70 10.9	M 12x80 10.9	M 12x70 10.9	M 12x95 10.9	M 14x90 10.9	M 16x140 8.8
tightening torque T_{A4} [Nm]	68	68	117	117	117	185	195
quantity	24	24	24	24	24	24	24

At first the output hub of the coupling is mounted onto the driven shaft and the flywheel flange is mounted to the flywheel (tightening torque T_{A2}).

Then the driven unit is put in its final position and aligned to the driving unit. Next step is the assembly of the rubber disc to the output hub (tightening torque T_{A3}). Finally the single bushes are bolted to the flywheel flange (T_{A4}). To achieve the desired precompression a substantial radial force must be exerted to the single bush in order to press it radially into its final position. We recommend as a first step to screw only one bolt without bushes and then to use this bolt as a support for a tool (e.g. large screw

driver) and to press the next bush down with this tool until the relevant bolt is tightened. Then always use the previously assembled adjacent bush as support in order to press down the next bush.

In order to avoid too much temporary radial load on the coupled shafts during assembly, we recommend always tightening alternate bolts 180° opposite to the previously tightened bolt.

After this procedure, the coupling is free of radial and axial forces, if it is well aligned. Also the transmitted torque does not create any reacting force. Only misalignments will cause relevant reacting forces.

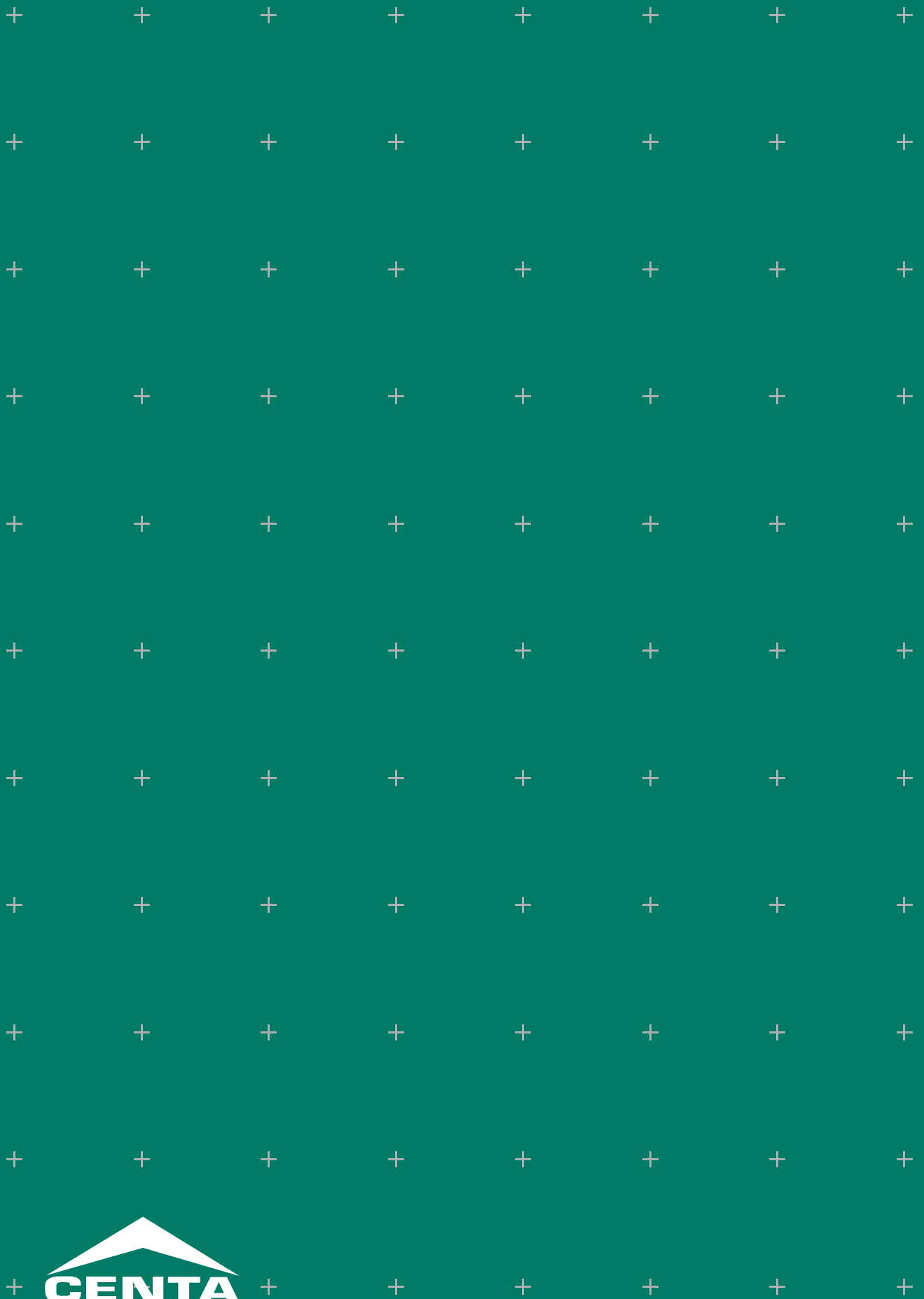

CENTA Antriebe Kirschey GmbH

Bergische Strasse 7 • P.O.B. 1125 • 42755 Haan • Germany
Phone: +49-(0)2129-912-0 • Fax: +49-(0)2129-2790
email: centa@centa.de • web: www.centa.info

Please refer to **www.centa.info**
to get information about the
various subsidiaries and the
international service from CENTA